

INSTALLATION INSTRUCTIONS

180 / 280 SERIES CONVENTIONAL DIRECT THROW SURFACE MOUNT BOLT LOCK

1. Determine the appropriate mounting configuration for your application (Header mount / Top Jamb mount, and or Side Jamb mount).

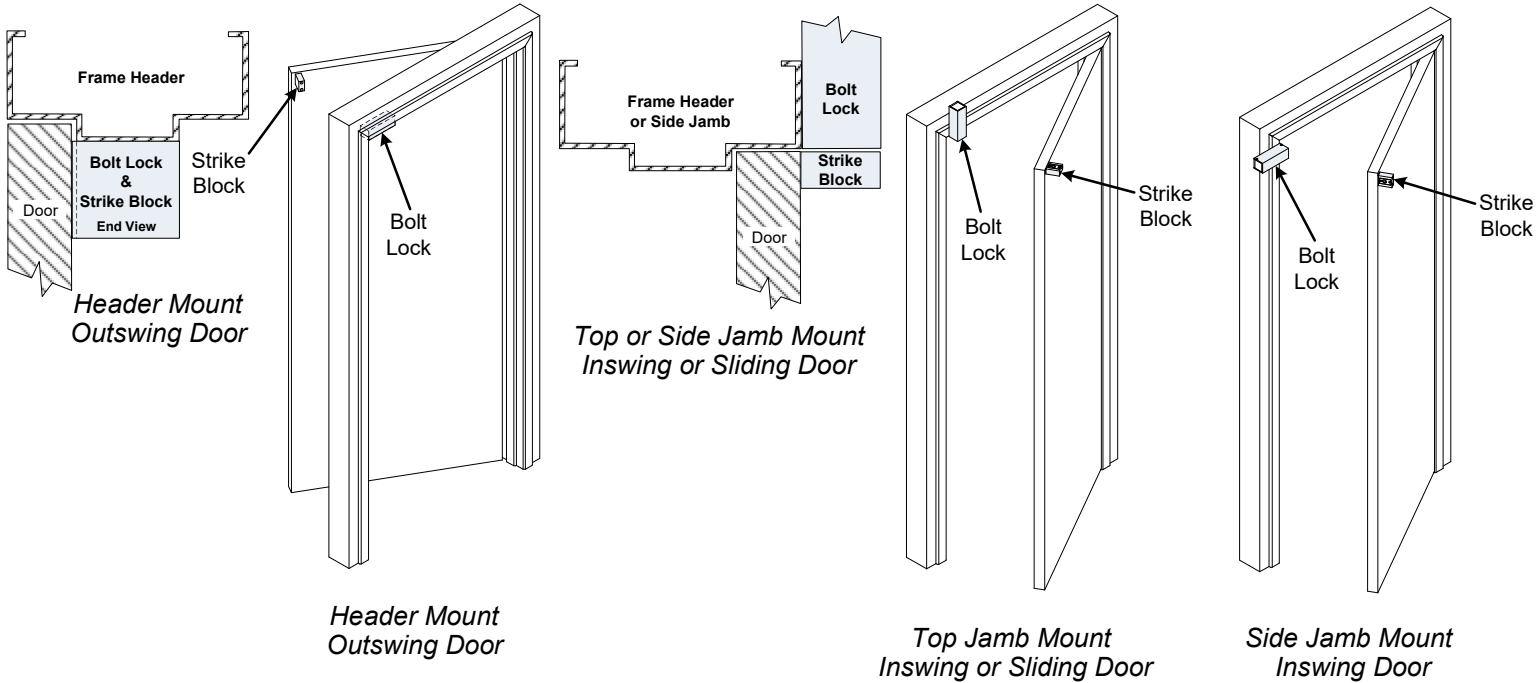

2. Determine the handing for your application. See examples below

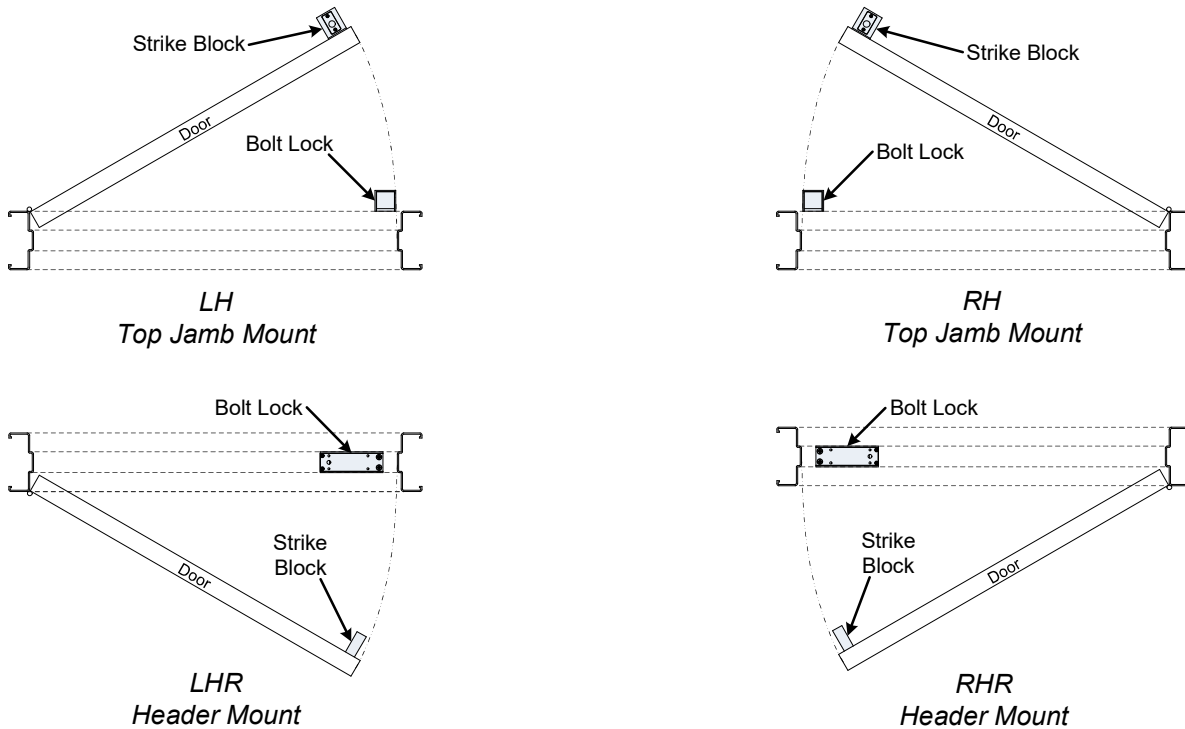

Any suggestions or comments to this instruction or product are welcome. Please contact us through our website or email engineer@sdsecurity.com

3. Remove the lock housing cover. Based on the mounting information determined on steps 1 & 2, adjust the Auto Relock Switch (ARS) in the bolt chamber bracket as described below.

Mounting Configuration	Auto-Relock Switch Orientation
Header Mounted - LHR	Perpendicular to the Mounting Plate
Header Mounted - RHR	Perpendicular to the Mounting Plate
Top Jamb or Side Jamb Swing - LH or RH	Perpendicular to the Mounting Plate
*Top Jamb Sliding Door - Left Slide	Parallel to the Mounting Plate
*Top Jamb Sliding Door - Right Slide	Parallel to the Mounting Plate
* Top Jamb Sliding Door - Requires a positive stop	

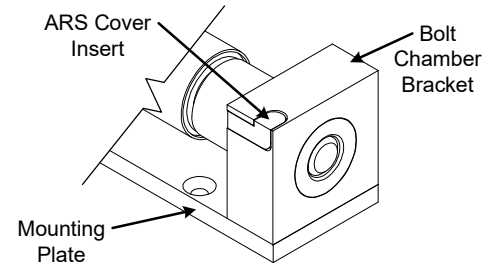

3a. Remove the ARS cover insert and install the ARS switch as required according to the mounting information above. Replace the ARS cover insert.

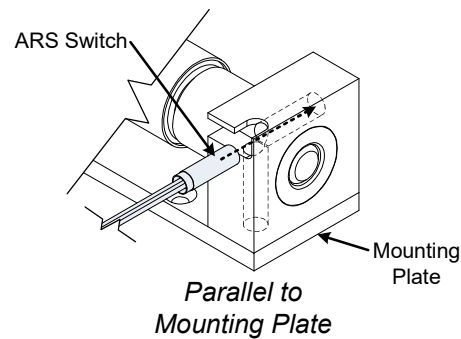
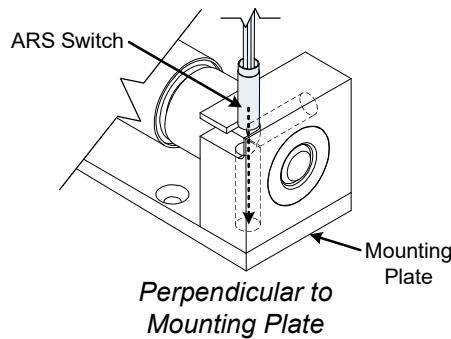

4. Based on the mounting information determined on steps 1 & 2, configure the Strike Block assembly as shown below.

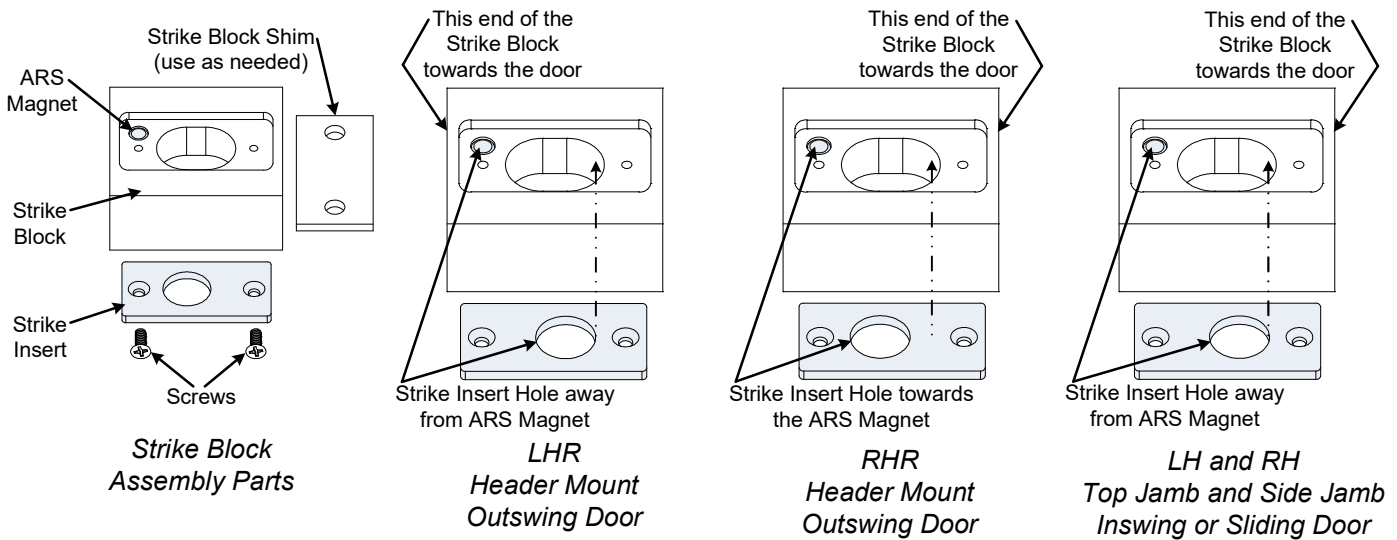

5. With template provided, mark and drill as follows:
 - Bolt lock: Holes 1, 2, 3, and 4 for #10 sheet metal screws or 10-32 x 1/2 machine screws.
 - Hole 8 – 3/8" diameter for wire.
 - Strike block: Holes 5 and 6 or 12 and 13 for 1/4 - 20 machine screw.
6. Tap holes as required.
7. Mount bolt lock and strike block.
8. Attach power leads as shown on page 3. When bolt is thrown, check alignment of bolt and strike. There should be no binding on the bolt. Leading part of strike block should be 1/8" away from the lock (1/8" is maximum distance). If this is correct, tighten mounting screws.
9. Check lock operation for any last adjustments.
10. Re-install lock housing cover.



The SDC PR-1000 Power Regulator module is included with the 180/280 bolt lock, and is required for proper operation. Installing the PR-1000 reduces the power consumption of the bolt locks after activation of the lock, allowing for a heat reduction to the bolt lock. Bypassing the PR-1000 will cause damage to the 180/280 bolt lock.

Solenoid Voltage Configuration:

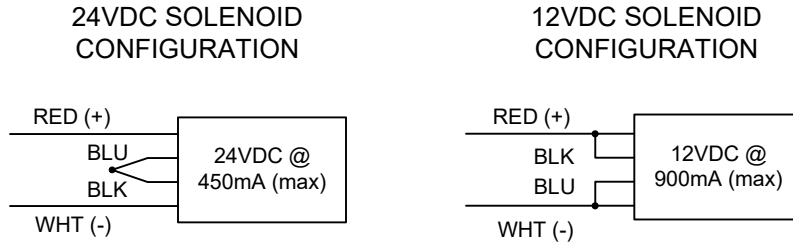

180 Wiring:

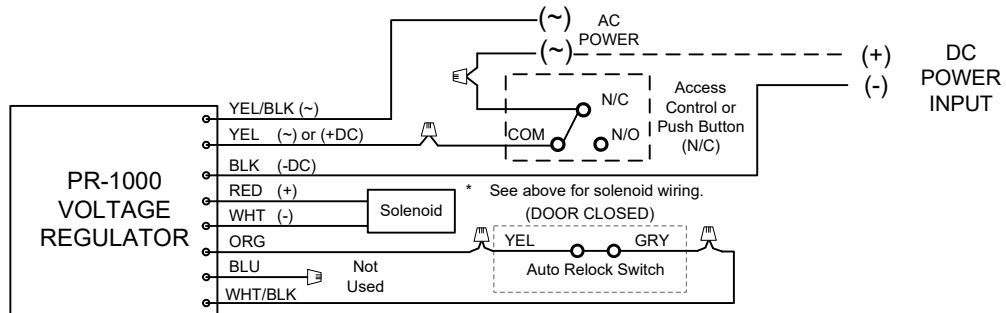

280 Wiring:

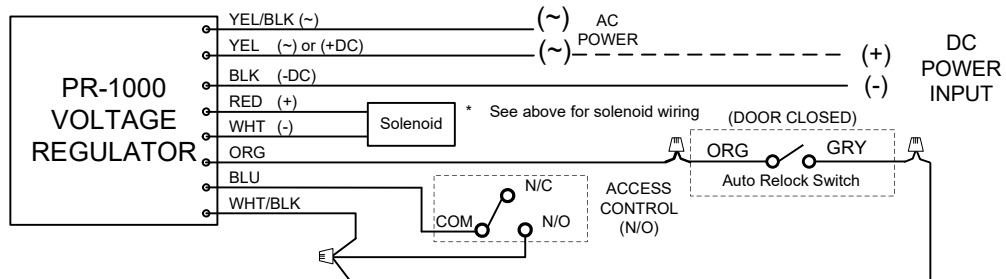

PR-1000 Input Voltage:

12/24 VDC/AC (+/-10%) DC voltage is recommended for optimal performance

SPECIFICATION

- DIMENSIONS: Lock: 2" x 2" x 6" / Strike Block: 2" x 2-1/4" x 1"
- FINISH: US28 standard
- BOLT: 1/2" diameter, 1/2" throw
- SOLENOID: .9 A @ 12VDC / .45 A @ 24VDC Dual Voltage Continuous Duty
- FUNCTION: 180, power to lock
280, power to unlock