

LR100 Series

Retrofit Electric Latch Retraction Kits



SDC's QuietDuo™ LR100 series retrofit electric latch retraction kits enable electric access control and dogging of panic and fire rated mechanical exit devices. When energized the motor retracts the exit device latch and pulls the pushpad into the dogged (depressed) position enabling momentary or sustained push and pull operation of the door. The latch retraction mechanism may be activated by an access control, remote control device or building automation system. No door sequencer required for a pair of manual doors when connected to a suitable power supply. The exit device always provides uninhibited egress.

The patented design was the first retrofit motorized electric latch retraction kit brought to market and has been recognized as the market leader ever since. **The use of a motorized electric latch retraction device provides several advantages over solenoids including lower current draw, quieter operation and greater durability over time.** Designed with cost savings in mind, SDC's LR100 series retrofit ELR kits not only eliminate the need for costly replacements of existing exit devices, but also provide **cost savings on installation and power requirements due to significantly less labor time and current draw** when compared to competitive retrofit kits. LR100 kits retrofit select exit device brands without removing the device from the door.

LR100 models are one unit completely housed within the rail of the device behind the access cover, whereas LR100-EM models are two piece space saver units, intended to gain up to one inch in spacing within the device, placing the controller board externally to accommodate smaller field cut devices for smaller openings or where space is limited within the rail.



MODELS

- LR100** Motorized Electric Latch Retraction Kit
- LR100-EM** Motorized Electric Latch Retraction Kit, External Module



STANDARD FEATURES

- Motorized electric latch retraction and dogging
- Panic and fire rated devices
- Simultaneous latch retraction, dogging and pushpad depression*
- High traffic use
- Low current draw
- Low energy operator compatible

* Select models do not retract pushpad, only retract the latch. See chart in applications.



APPLICATIONS

SDC's retrofit motorized electric latch retraction kits are designed to be field installed. However, SDC also offers to install the kit at SDC's factory. Simply send the mechanical exit device

brand of your choice to SDC for factory install. The table below outlines exit device compability and part numbers for both field install and factory installed LR100 kits.

Brand	Opening	Rim	SVR	CVR	Mortise	Field Install
Adams Rite	36" - 48"	8800 / 3700	8100 / 8200 / 3100	8500 / 8600 / 3600	-----	LR100ARK*
Adams Rite	30"	8700 / 8800 / 3700	8100 / 8200 / 3100	8500 / 8600 / 3600	-----	LR100ARK-EM*
Adams Rite	36" - 48"	EX88 / EX89	-----	EX76	-----	LR100AREXK-EM
Arrow	36" - 48"	S1250	S1150	-----	-----	LR100AWK
Arrow	36"	ED910	-----	-----	-----	LR100AWK-ED910
Corbin Russwin	36" - 48"	ED5200 / ED4200	ED5400	ED4800 / ED5800	-----	LR100CRK
Corbin Russwin	30"	ED5200 / ED4200	ED5400	ED4800 / ED5800	-----	LR100CRK-EM
Cal-Royal	36"	7700 / F7700	7760 / F7760	-----	-----	LR100CAK
Cal-Royal	36"	GLS9800	-----	GLSCVR9800	-----	LR100CAK-9800
Cal-Royal	36"	2200 / F2200 / 9800 / F9800	2260 / F2260 / 9860 / F9860	-----	-----	LR100CAK-EM
Design Hardware	36"	1000R	1000V	-----	-----	LR100DHK
Detex	36"	10 / 40	20 / 50	80 / 81 / 62 / 63	-----	LR100DXK
Dorma	36"	9300 / F9300	9400 / F9400	-----	-----	LR100DAK
Dor-O-Matic	36"	1790	-----	1690	-----	LR100FAK
Dor-O-Matic	33"	1790	-----	1690	-----	LR100FAK-EM
Dor-O-Matic	36"	1590	-----	1490	-----	LR100DMK
Falcon	36"	25-R / F-25-R / 24-R / F-24-R	25-V / F-25-V / 24-V / F-24-V	25-C / F-25-C / 24-C / F-24-C	-----	LR100FRK
First Choice	36"	3790	-----	3690	-----	LR100FCK
First Choice	30"	3790	-----	3690	-----	LR100FCK-EM
Hager	36" - 48"	4501-RIM	4501-SVR	-----	-----	LR100HK
Hager	30"	4501-RIM	4501-SVR	-----	-----	LR100HK-EM
IDC	36" - 48"	8610 / 8810 / 8510 / 8710	8630 / 8830 / 8530 / 8730	8650 / 8850 / 8550 / 8750	8620 / 8820	LR100IDCK
IDC	30"	8610 / 8810 / 8510 / 8710	8630 / 8830 / 8530 / 8730	8650 / 8850 / 8550 / 8750	8620 / 8820	LR100IDCK-EM
Jackson	36"	2095	-----	2085	-----	LR100JAK
Marks	36"	M9900	M9900VR	-----	-----	LR100MDK
Marks	36"	M8800	-----	-----	-----	LR100M88K
Marshall Best	36"	Q1100 / QF1100	Q1200 / QF1200	-----	-----	LR100MBSK
Marshall Best	30"	Q1100 / QF1100	Q1200 / QF1200	-----	-----	LR100MBSK-EM
Pamex	36" - 48"	EF9000	EF9000V	EF9020V	-----	LR100PAK
Pamex	30"	EF9000	EF9000V	EF9020V	-----	LR100PAK-EM
PDQ	36" - 48"	6200R	6200V	-----	-----	LR100PDQK
PHI (Precision)	36" - 48"	2100 / 2400 / 5100	2200LBR / 5200LBR	2800LBR / 2600	-----	LR100PDK

* Models do not retract pushpad, only retract the latch.

Continued on next page.

APPLICATIONS

SDC's retrofit motorized electric latch retraction kits are designed to be field installed. However, SDC also offers to install the kit at SDC's factory. Simply send the mechanical exit device

brand of your choice to SDC for factory install. The table below outlines exit device compability and part numbers for both field install and factory installed LR100 kits.

Brand	Opening	Rim	SVR	CVR	Mortise	Field Install
Sargent	36" - 48"	8500 / 8800	8700	8400 / 8600	8300 / 8900	LR100SGK
Sargent	30"	8500 / 8800	8700	8400 / 8600	8300 / 8900	LR100SGK-EM
SDC	36" - 48"	S6100	S6200	S6800	S6300	LR100SDCK
SDC	30"	S6100	S6200	S6800	S6300	LR100SDCK-EM
Stanley K2	36" - 48"	QED111	QED114	QED124	-----	LR100K2K
Stanley K2	30"	QED111	QED114	QED124	-----	LR100K2K-EM
Tell	36"	9500	9400	-----	-----	LR100TEK
TownSteel	36" - 48"	ED1100	ED1200	ED1300	-----	LR100TSK
TownSteel	30"	ED1100	ED1200	ED1300	-----	LR100TSK-EM
TownSteel	36"	ED5500	ED5600	-----	-----	LR100TSK-55/56
TownSteel	36"	ED6500	ED6700	-----	-----	LR100TSK-65/67
Von Duprin	36" - 48"	22	2227	-----	-----	LR100VDK-22*
Von Duprin	30"	22	2227	-----	-----	LR100VDK-22-EM*
Von Duprin	36" - 48"	22	2227	-----	-----	LR100VDK-22V2
Von Duprin	30"	22	2227	-----	-----	LR100VDK-22V2-EM
Von Duprin	36" - 48"	98 / 99 / 33A / 35A	9827 / 9927 / 3327A / 3527A 9857 / 9957	9847 / 9947 / 3347A / 3547A, 3348A / 3548A	9875 / 9975	LR100VDK
Von Duprin	30"	98 / 99 / 33A / 35A	9827 / 9927 / 3327A / 3527A 9857 / 9957	9847 / 9947 / 3347A / 3547A, 3348A / 3548A	9875 / 9975	LR100VDK-EM
Yale	36" - 48"	7100 / 7100-2 / 7200	7110 / 7210	7120 / 7220	-----	LR100YDK
Yale	30"	7100 / 7100-2 / 7200	7110 / 7210	7120 / 7220	-----	LR100YDK-EM
Yale	36" - 48"	6100ED	-----	-----	-----	LR100Y6K
Yale	30"	6100ED	-----	-----	-----	LR100Y6K-EM

* For Von Duprin 22 models manufactured in 2021 or earlier.

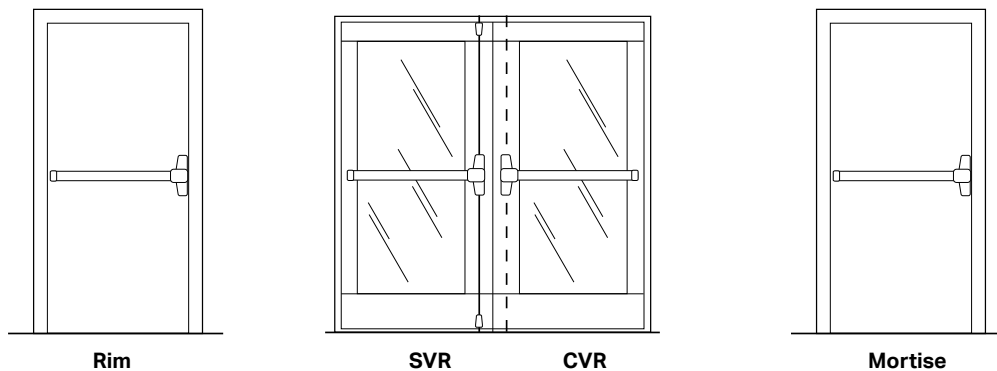

SPECIFICATIONS

	LR100	LR100-EM
Type	Retrofit ELR Kit	Retrofit ELR Kit, External Module
Input	24 VDC \pm 10%	24 VDC \pm 10%
Current Draw	1.5 Amp Inrush* 200 mA Continuous	1.5 Amp Inrush* 200 mA Continuous
Latch Retraction	Motorized	Motorized

* SDC 602 power controllers will accommodate 1.5 amp inrush.

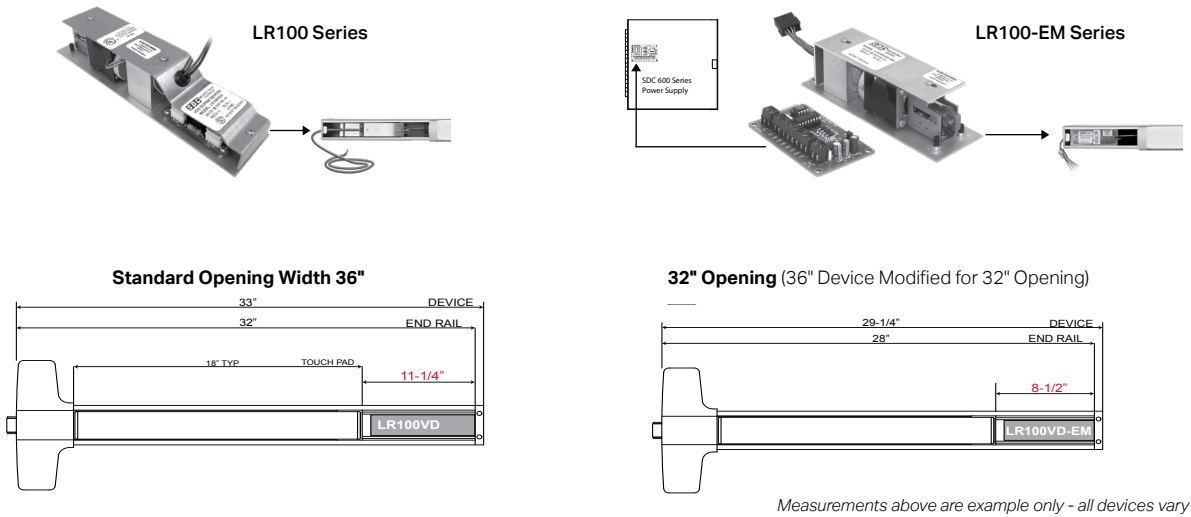

RECOMMENDED POWER SUPPLY

For a single door, use SDC model 602RF. For simultaneous pair of doors, use SDC model 602RFUR1 or 634RF.

Select LR100 models require SDC model 631RF.

	SINGLE DOOR	SIMULTANEOUS PAIR OF DOORS
LR100ARK	631RF	631RFUR-1 or 634RF
LR100FAK	631RF	631RFUR-1 or 634RF
(All other LR100 models)	602RF	602RFUR-1 or 634RF

When using another manufacturer's power supply, a linear, regulated and filtered supply with a minimum rating of 2 amp per LR100 kit is recommended.

CERTIFICATIONS

UL 305 Panic Hardware
 UL 10C Positive Pressure Fire Tests
 ULC-S104 Standard Method for Fire Tests of Door Assemblies
 ANSI/BHMA A156.3 Grade 1

HOW TO ORDER

FOLLOW STEPS FOR ORDERING

 Designates optional step

1| SPECIFY MODEL*

Adams Rite	LR100ARK	LR100ARK-EM	LR100AREXK-EM	----
Arrow	LR100AWK	LR100AWK-ED910	----	----
Corbin Russwin	LR100CRK	LR100CRK-EM	----	----
Cal-Royal	LR100CAK	LR100CAK-9800	LR100CAK-EM	----
Design Hardware	LR100DHK	----	----	----
Detex	LR100DXK	----	----	----
Dorma	LR100DAK	----	----	----
Dor-O-Matic	LR100FAK	LR100FAK-EM	LR100DMK	----
Falcon	LR100FRK	----	----	----
First Choice	LR100FCK	LR100FCK-EM	----	----
Hager	LR100HK	LR100HK-EM	----	----
IDC	LR100IDCK	LR100IDCK-EM	----	----
Jackson	LR100JAK	----	----	----
Marks	LR100MDK	----	LR100M88K	----
Marshall Best	LR100MBSK	LR100MBSK-EM	----	----
Pamex	LR100PAK	LR100PAK-EM	----	----
PDQ	LR100PDQK	----	----	----
PHI (Precision)	LR100PDK	----	----	----
Sargent	LR100SGK	LR100SGK-EM	----	----
SDC	LR100SDCK	LR100SDCK-EM	----	----
Stanley K2	LR100K2K	LR100K2K-EM	----	----
Tell	LR100TEK	----	----	----
Townsteel	LR100TSK	LR100TSK-EM	LR100TSK-55/56	LR100TSK-65/67
Von Duprin	LR100VDK-22**	LR100-VDK-22-EM**	LR100VDK	LR100VDK-EM
	LR100VDK-22V2	LR100-VDK-22V2-EM		
Yale	LR100YDK	LR100YDK-EM	LR100YDK-42/48	----
	LR100Y6K	LR100Y6K-EM		

* See chart in applications for complete for complete details on exit device compatibility.

** For Von Duprin 22 models manufactured in 2021 or earlier.

STEP NUMBER: 1

ORDERING EXAMPLE: **LR100VDK**

RELATED PRODUCTS

RETROFIT MONITORING KITS

In addition to retrofit motorized electric latch retraction kits, SDC also offers a variety of retrofit monitoring kits for field installation. Request-to-exit (REX) monitoring kits can be used to monitor

the pushpad/dogged status on an exit device. The table below outlines exit device compatibility and part numbers for both request-to-exit (REX) and latch status (LS) monitoring kits.

Brand	Rim	SVR	CVR	Mortise	REX	LS
Adams Rite	8700 / 8800 / 3700	8100 / 8200 / 3100	8500 / 8600 / 3600	-----	LRAR1R	-----
Adams Rite	EX88 / EX89	-----	EX76	-----	LRAREX1R	-----
Corbin Russwin	ED5200 / ED4200	ED5400	ED4800 / ED5800	-----	LRRCR1R	LRRCR1L
Cal-Royal	7700 / F7700	7760 / F7760	-----	-----	LRCA2R	-----
Cal-Royal	9800	-----	GLSCVR9800	-----	LRCA1R	-----
Detex	10 / 40	20 / 50	80 / 81 / 62 / 63	-----	LRDX1R	-----
Dorma	9300 / F9300	9400 / F9400	-----	-----	LRDA1R	-----
Dor-O-Matic	1790	-----	1690	-----	LRFA1R	-----
Falcon	25-R / F-25-R / 24-R / F-24-R	25-V / F-25-V / 24-V / F-24-V	25-C / F-25-C / 24-C / F-24-C	-----	LRFR1R	-----
First Choice	3790	-----	3690	-----	LRFC1R	-----
Hager	4501-RIM	4501-SVR	-----	-----	LRH1R	LRH1L
IDC	8610 / 8180 / 8510 / 8710	8630 / 8830 / 8530 / 8730	8650 / 8850 / 8550 / 8750	8620 / 8820	LRIDC1R	LRIDC1L
Kawneer	1786	-----	-----	-----	LRKWK1R	LRKWK1L
Marks	M9900	M9900VR	-----	-----	LRMD1R	-----
Pamex	EF9000	EF9000V	EF9020V	-----	LRPA1R	LRPA1R
Pamex	EF9000	EF9000V	EF9020V	-----	LRPA1RL*	LRPA1RL*
PHI (Precision)	2100 / 2400	-----	-----	-----	LRP1R	LRP1L
PHI (Precision)	-----	2200LBR	2800LBR / 2600	-----	LRP2R	LRP2L
Sargent	8800	8700	-----	-----	LRSG1R	-----
Sargent	8500 / 8800	8700	8400 / 8600	8300 / 8900	LRSG2R	-----
SDC	S6100	S6200	S6800	S6300	LRSDC1R	LRSDC1L
Stanley K2	QED111	QED114	QED124	-----	LRK2R	-----
TownSteel	ED1100	ED1200	ED1300	-----	LRTS1R	-----
TownSteel	ED5500	ED5600	-----	-----	LRTS2R	-----
Von Duprin	22	2227	-----	-----	LRVD2R	LRVD2L
Von Duprin	98 / 99	9827 / 9927 / 9857 / 9957	9847 / 9947	9875 / 9975	LRVD1R	LRVD1L
Von Duprin	33A / 35A	3327A / 3527A	3347A / 3547A	-----	LRVD3R	LRVD3L*
Yale	7100 / 7100-2 / 7200	7110 / 7210	7120 / 7220	-----	LRV1R	LRV1L
Yale	6100ED	-----	-----	-----	LRV61R	-----

* The Pamex LRPA1RL kit is both request-to-exit (REX) and latch status (LS).

** Available for 33A/35A rim devices only.